



## **INDUSTRIAL EQUIPMENT**

# **ROTOMATIC**

## **AUTOMATIC DIE CUTTER**



**QUICK, ACCURATE AUTOMATIC  
OPERATION**

**GET CLEANER CUTS WITH LESS  
PRESSURE TO EXTEND DIE LIFE**

### **Features Available on the Rotomatic**

- **Bi-Flex Cutting Principle (Cutting Force Concentrated Between Pressure Rolls)**
- **6" Diameter Rigid Steel Pressure Rolls**
- **Extra Heavy Duty Self Aligning Roller Bearings**
- **Automatic Pneumatic Chase Opening And Closing**
- **Die Mounting In Chase Or Bed**
- **Two Bed Sizes (RB-3340, 3350)**
- **Calibrated Adjustment For Roll Height And Cutting Pressure**
- **Chase Interlocking Switches**
- **Two Horsepower Stationery Motor Drive And Single Direction Chain Drive**
- **Double Safety Start Switches**
- **Optional Single Cut Cam Actuation Available**
- **Stainless Steel Or Polypropelene Cutting Plate**

# **ONE YEAR WARRANTY**

## Machine Specifications

<b>Models</b>	<b>RB3340, RB3350</b>
<b>Cutting Area</b>	<b>33" W, 40" L (3340)</b> (84 W, 102 L cm)
	<b>33" W, 50" L (3350)</b> (84 W, 127 L cm)
<b>Product Height</b>	<b>5 1/2" Maximum</b> (14 cm)
<b>Bed Height</b>	<b>34" (86 cm)</b>
<b>Minimum Rule Size</b>	<b>.042 (3 pt) W x 1 1/8"</b> (1.06 x 2.85 cm)
<b>Maximum Die Weight</b>	<b>60 lbs. (27 kg)</b>
<b>Power Requirement</b>	<b>208, 220, 240, 440 V</b> <b>Three Phase, 6 Amp</b>
<b>Air</b>	<b>1 cf/cycle @ 80 psi min</b>
<b>Cycle Speed</b>	<b>7 Seconds</b>
<b>Weight</b>	<b>2,600 lbs. (1,170 kg)</b>

## Machine Footprint

### TOP VIEW

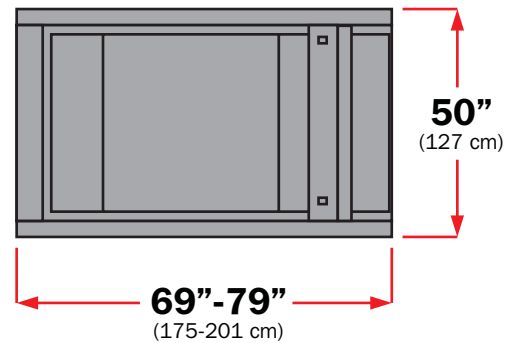

### SIDE VIEW

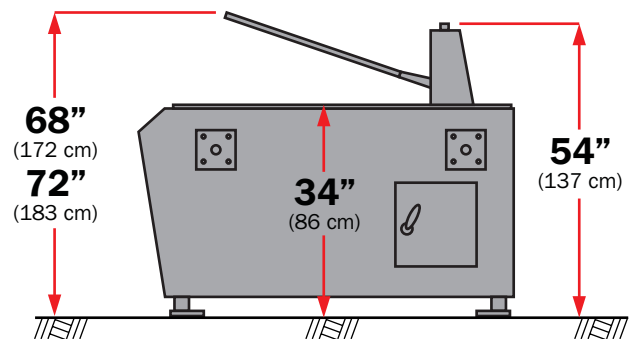

**ONE YEAR WARRANTY**

## Machine Options

- Spare Parts Kit
- Cutting Plate (Poly Or Stainless Steel)
- Common Carrier Crating
- Camming Actuation

For Additional Product Information, Contact:



**AMPAK A DIVISION OF HEAT SEAL LLC**  
4580 EAST 71ST STREET CLEVELAND OHIO 44125

PHONE (216)588 0088 TOLL FREE (877)261 9711 FAX (216)341 2163  
WORLD WIDE WEB [www.ampakco.com](http://www.ampakco.com) E-MAIL [custserv@ampakco.com](mailto:custserv@ampakco.com)

