



INDUSTRIAL EQUIPMENT

MODEL CP-4200

CLEAR-PAK ROTARY BLISTER SEALER



**FULLY AUTOMATIC
OPERATION**

**SEALS INDIVIDUAL PACKAGES
OF MANY DIFFERENT SIZES**

Features Available On The CP-4200 Blister Sealer

- Seals All Rigid Thermoplastic Blisters
- Up To Ten Cycles Per Minute
- Adjustable Sealing Pressure
- Temperature Range Of Up To 600° F (315° C)
- Seal Area 14" By 18" Per Station
- Easy Setup And Operation
- Tooling Allows For Rapid Change Over
- Compact Design Allows For Easy Loading/Unloading
- Permanently Lubricated Bearings
- User Friendly Control Panel
- Integrated Hot Plate Safety System
- Shipped Set Up And Ready To Use

ONE YEAR WARRANTY

Machine Specifications

Sealing Area	14" W, 18" L (36 W, 46 L cm)
Overall Dimensions	58" H, 59" W, 75" L (147 H, 150 W, 191 L cm)
Power Requirement	220 Volt, 15 Amp Single Phase
Temperature	Resistance Heat: 150° - 600° F (66° - 315° C)
Cycle Time	Up to 10 Cycles/Min.
Sealing Time	1.5 to 30 Seconds
Sealing Pressure	35-60 psi
Air	.062 cfm @ 80 psi
Weight	480 lbs. (218 kg)

ONE YEAR WARRANTY

Machine Options

• Casters

• Foot Switch

Machine Footprint

TOP VIEW

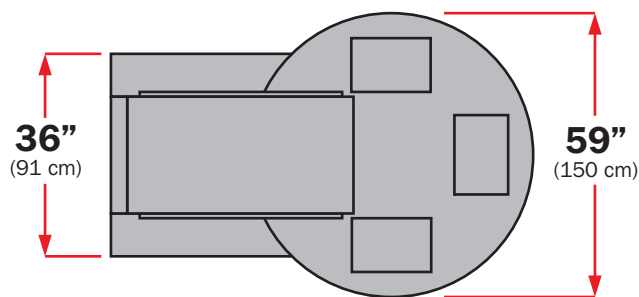

FRONT VIEW

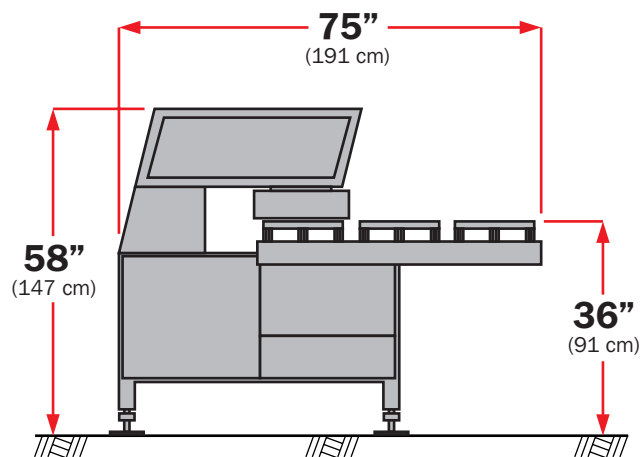

NOTE Recommended Blister:
3-20 Mil Rigid Thermoplastic, 1/4" Flange Width

Recommended Board:
Coated Boxboard and S.B.S., 15-32 PT Board

For Additional Product Information, Contact:



AMPAK A DIVISION OF HEAT SEAL LLC
4580 EAST 71ST STREET CLEVELAND OHIO 44125

PHONE (216)588 0088 TOLL FREE (877)261 9711 FAX (216)341 2163
WORLD WIDE WEB www.ampakco.com E-MAIL custserv@ampakco.com

