



INDUSTRIAL EQUIPMENT

DURAMATIC

AUTOMATIC SKIN/DIE CUTTING PACKAGING SYSTEM



FULLY INTEGRATED FLEXIBLE SKIN PACKAGING AND DIE CUTTING SYSTEM

Features Available On The Duramatic Automatic Skin Machine

- Custom Designed To Your Optimal Sheet Size, Eliminating Waste
- Runs Up To Twelve Cycles Per Minute
- Unique Pin Register System For Precise Indexing Throughout Operation
- Optional Self-Contained Sheet Feeder
- Optional Product Placement Template For Quick Loading
- Optional Magnetic Loading Bed For Stabilizing Small Products
- Spirad[®] Heaters With Separately Adjustable Zones
- Product "Out Of Position" Detector Prevents Damage To Products And Dies
- Eighty Ton Die Cutter With Shelf Style Die Mounting For Fast Change Over
- Dies Can Be Changed In As Little As Two Minutes
- Finished Parts Can Be Automatically Stripped From Web Material

ONE YEAR WARRANTY

Machine Specifications

Trimmed Board (Machine Direction)	12" to 18" (30 to 46 cm)
Trimmed Board (Across Mach. Direct.)	14" to 24" (36 to 61 cm)
Max. Product Height	3 1/2" (9 cm)
Film Capacity	26 1/2" W, 9" OD, 3" ID (67 W, 23 OD, 8 ID cm)
Overall Dimensions	66" H, 44" W, 270" L (168 H, 112 W, 686 L cm)
Power Requirements	228 Volt, 90 Amp Three Phase
Air	5 cfm @ 80-100 psi
Vacuum	1 1/2 HP Pos. Disp. Pump 12 Gallon Surge Tank
Cycle Speeds	4 to 12 per minute
Weight	4,000 lbs. (1,815 kg)

ONE YEAR WARRANTY

Machine Footprint

TOP VIEW

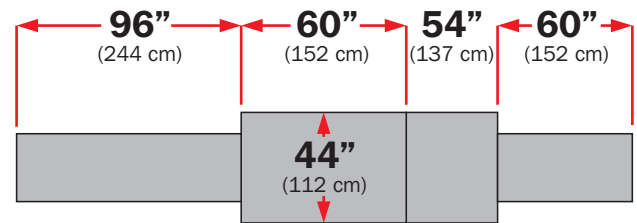

FRONT VIEW

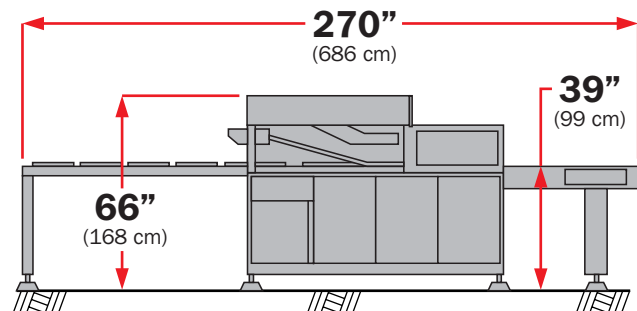

NOTE Recommended Films:
4 mil Polyethylene and Surlyn 1601

Recommended Board:
S.B.S. - Coated and Punched

Machine Options

- Spare Parts Kit
- Automatic Package Stripping
- Automatic Sheet Feeder
- Low Profile Product Detection
- Magnetic Loading Bed
- Two Station Template Loader

For Additional Product Information, Contact:



AMPAK A DIVISION OF HEAT SEAL LLC
4580 EAST 71ST STREET CLEVELAND OHIO 44125

PHONE (216)588 0088 TOLL FREE (877)261 9711 FAX (216)341 2163
WORLD WIDE WEB www.ampakco.com E-MAIL custserv@ampakco.com

